

# Prefix-000012-Suffix

N/A	N/A	46100008	KIT, SPRING	N/A	N/A	NOTED
N/A	N/A	6V150113	KIT, SEAL, FKM	N/A	NOTED	N/A
N/A	N/A	46000019	KIT, SEAL, STANDARD	NOTED	N/A	N/A
13	1	39T55003	GASKET, (-124)	X	X	X
12	1	81591301	DISK, PIVOT, BALL, SC, 2600, SA			X
11	1	81531301	RETAINER, SC, 2600			
10	1	49001905	BREATHER, 1/4 BSPP			
9	1	47511300	PLUNGER, SC, 11.6 kN			
8	1	39053000	WIPER, SNAP-IN, (7/8)	X	X	
7	1	39011046	SEAL, BEVEL W/HEEL INSERT, 7/8 x 1/8 x 1 1/8	X	39V11046	
6	1	39011027	SEAL, BEVEL, 1-1/16 x 3/32 x 1-1/4	X	39052012	
5	1	39000020	O-RING, (-005)	X	39051007	
4	2	23600002	BALL, STEEL, ALLOY, .250	X	X	X
3	1	23313010	SPRING, COMPRESSION			X
2	1	23313009	SPRING, COMPRESSION			X
1	1	21500010	SCREW, CAP, BTNH, M12 X 20, ALY			
<b>No.</b>	<b>QTY</b>	<b>PART No.</b>	<b>DESCRIPTION</b>	<b>Standard Seal Kit</b>	<b>FKM Seal Kit</b>	<b>Spring Kit</b>

Assemble with lip side facing bottom of body

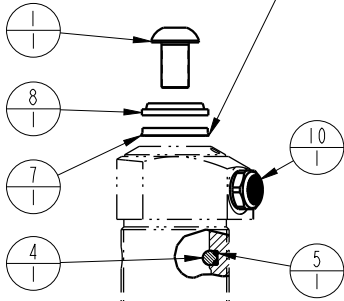

Body - Not Replaceable

Lubricate all seals with clean hydraulic fluid prior to assembly.  
Do Not Use Silicone Based Lubricants.

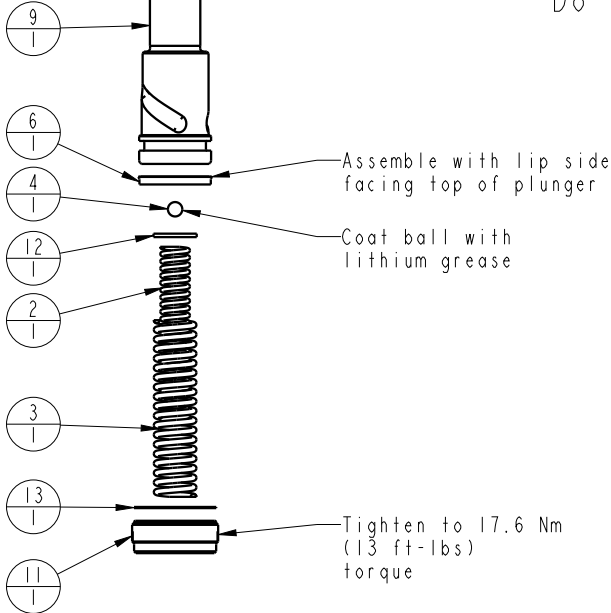

Assemble with lip side facing top of plunger

Coat ball with lithium grease

Tighten to 17.6 Nm (13 ft-lbs) torque



## PARTS LIST



VEKTEK, INC.  
1334 E. SIXTH AVE. P.O. BOX 625  
EMPORIA, KS. 66801 U.S.A.

ASSEMBLIES AFFECTED

PARTS LIST, ASSY, SC, TB, 11.6, SA, VersaCom

41-5011-11

41-5011-12

41-5011-15

SIZE  
A

MPL1512

REV  
N

SHEET 1 OF 1

N	5877	RELEASE	JDW	01/26/26
REV	IN ACCORDANCE WITH ECN	EFFECTIVE DATE	REVISED BY	DATE
DRW BY:	MARCOTTE	DRAWING STATUS: <b>Released</b>		
DATE:	04/09/99	PRODUCTION APPROVED FOR RELEASED STATUS ONLY		

FORM FEG035\_PL.A.SIZE, REV. B